



X500n, X502n

Maintenance Guide

Contents

Maintaining the printer.....	3
Storing supplies.....	3
Conserving toner.....	3
Cleaning the printer.....	3
Cleaning the exterior of the printer.....	3
Cleaning the scanner glass.....	4
Cleaning the dust-proof glass.....	5
Ordering supplies.....	10
Ordering toner cartridges.....	10
Ordering a fuser.....	11
Ordering a photodeveloper cartridge.....	11
Ordering a waste toner bottle.....	11
Moving the printer.....	12
Before moving the printer.....	12
Locking the scanner.....	12
Removing the printer from the 530-sheet drawer.....	14
Moving the printer to another location.....	17
Setting the printer up in a new location.....	17

Maintaining the printer

Periodically, certain tasks are required to maintain optimum print quality.

Storing supplies

Choose a cool, clean storage area for the printer supplies. Store supplies right side up in their original packing until you are ready to use them.

Do not expose supplies to:

- Direct sunlight
- Temperatures above 35°C (95°F)
- High humidity above 80%
- Salty air
- Corrosive gases
- Heavy dust

Conserving toner

Toner Saver mode enables you to conserve toner. When Toner Saver mode is enabled, print may appear lighter. To enable Toner Saver mode:

- 1 From the control panel, press ▲.
- 2 Press ▲ or ▼ repeatedly until **Machine Settings** appears, and then press ✓.
- 3 Press ▲ or ▼ repeatedly until **Toner Saver Mode** appears, and then press ✓.
- 4 Press ▲ or ▼ repeatedly until **On** appears, and then press ✓.
- 5 Press ✖ to return to the **Ready** state.

Note: Toner Saver mode is not recommended when you are printing photos or grayscale images.

Cleaning the printer

If print quality problems such as streaking occur, follow these cleaning procedures.

Warning—Potential Damage: Do not put water directly on the printer or use ammonia-based cleaners or volatile solvents, such as thinner, on the printer.

Cleaning the exterior of the printer

- 1 Make sure that the printer is turned off and unplugged from the wall outlet.



CAUTION—SHOCK HAZARD: To avoid the risk of electric shock, unplug the power cord from the wall outlet and disconnect all cables to the printer before proceeding.

- 2 Remove paper from the paper support and paper exit tray.

- 3 Dampen a clean, lint-free cloth with water.

Warning—Potential Damage: Do not use household cleaners or detergents, as they may damage the finish of the printer.

- 4 Wipe only the outside of the printer, making sure to remove any ink residue that has accumulated on the paper exit tray.

Warning—Potential Damage: Using a damp cloth to clean the interior may cause damage to your printer.

- 5 Make sure the paper support and paper exit tray are dry before beginning a new print job.

Cleaning the scanner glass

Clean the scanner glass if you encounter print quality problems, such as streaks on copied or scanned images.

- 1 Slightly dampen a soft, lint-free cloth or paper towel with water.
- 2 Open the scanner cover.



- 3 Wipe the scanner glass (which includes the document glass and ADF glass) until it is clean and dry.
- 4 Wipe the white underside of the scanner cover and the white plastic input guides until they are clean and dry.
Note: The white plastic input guides are located on the scanner cover underneath the ADF on the left side.
- 5 Close the scanner cover.

Cleaning the dust-proof glass

Clean the dust-proof glass if you encounter print quality problems.

- 1 Turn the printer off.
- 2 Pull the front door release latch forward, and gently lower the front door.

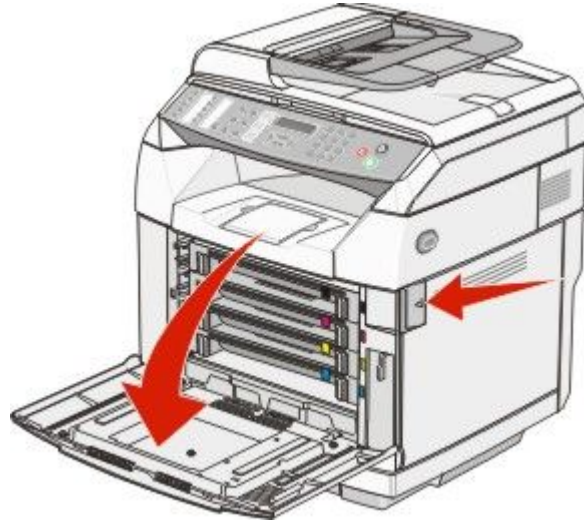

- 3 Remove the toner cartridges one at a time.

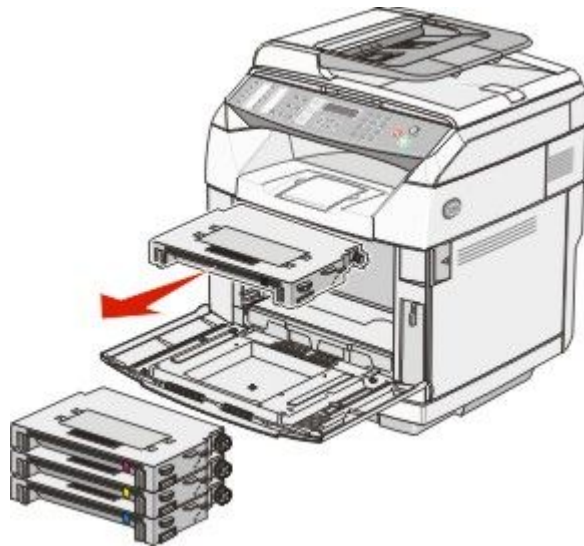

4 Open the top door.

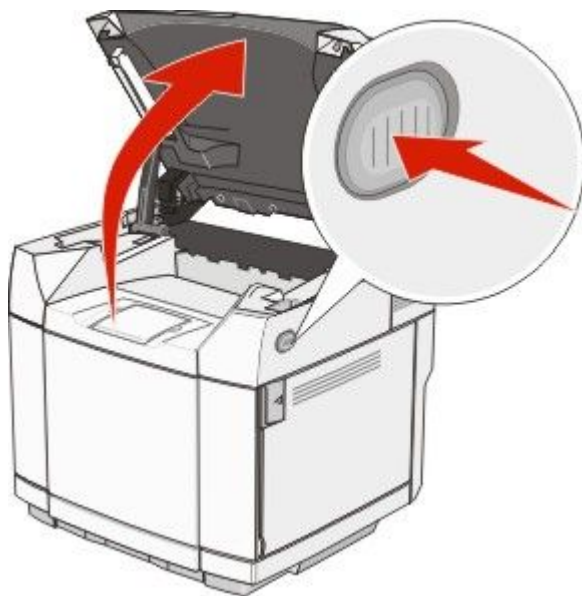

5 Push the latches toward each other to release the photodeveloper cartridge.

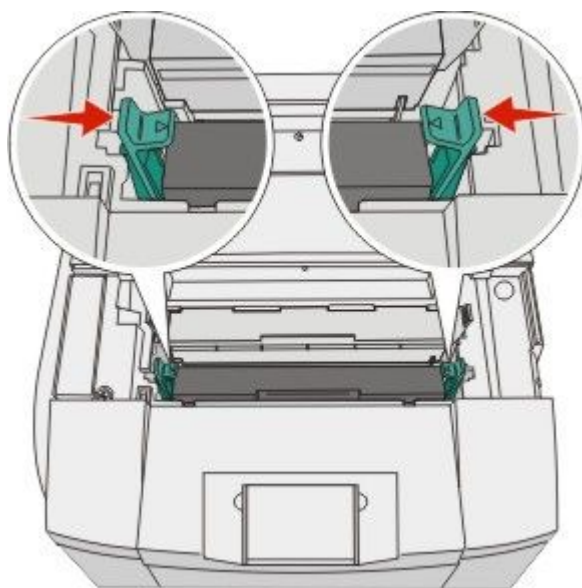

6 Grasp the handle, and pull the photodeveloper cartridge straight up and out.

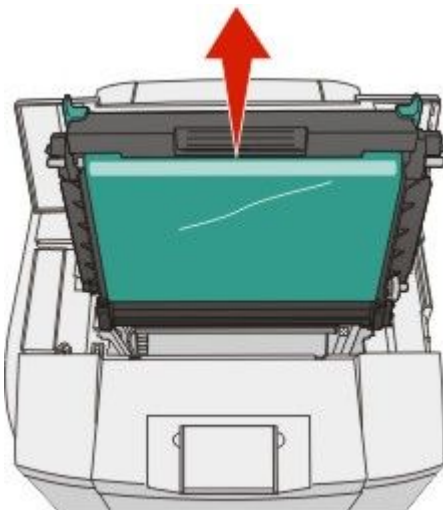

7 Pull on the tabs to lift the dust-proof glass cover.

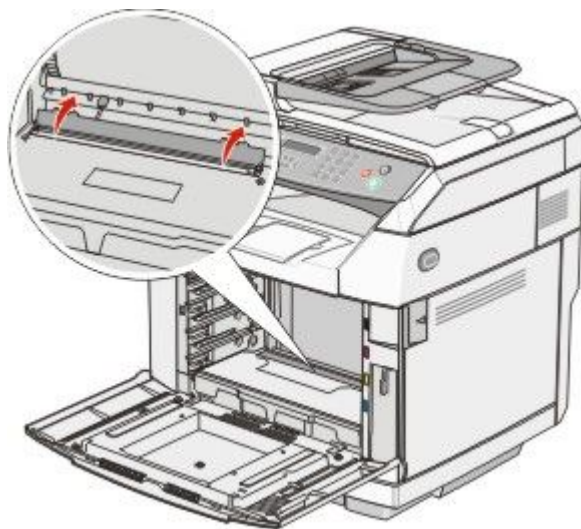

8 Gently wipe the dust-proof glass using a clean, dry, lint-free cloth.

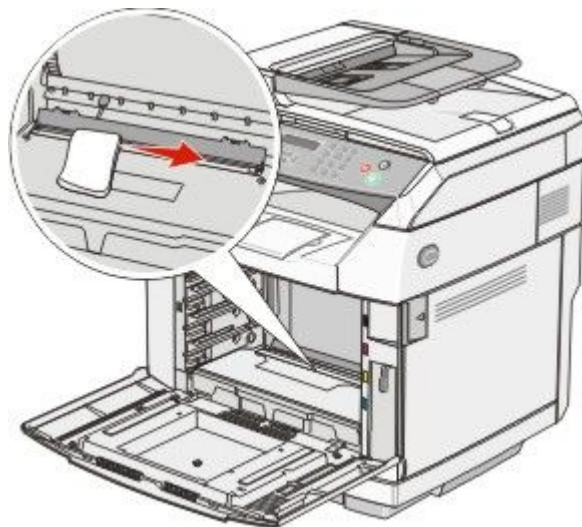

9 Push the dust-proof glass cover down.

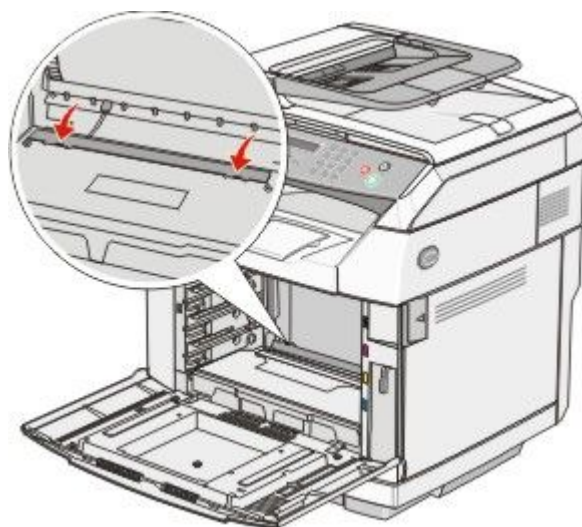

10 Replace the photodeveloper cartridge.

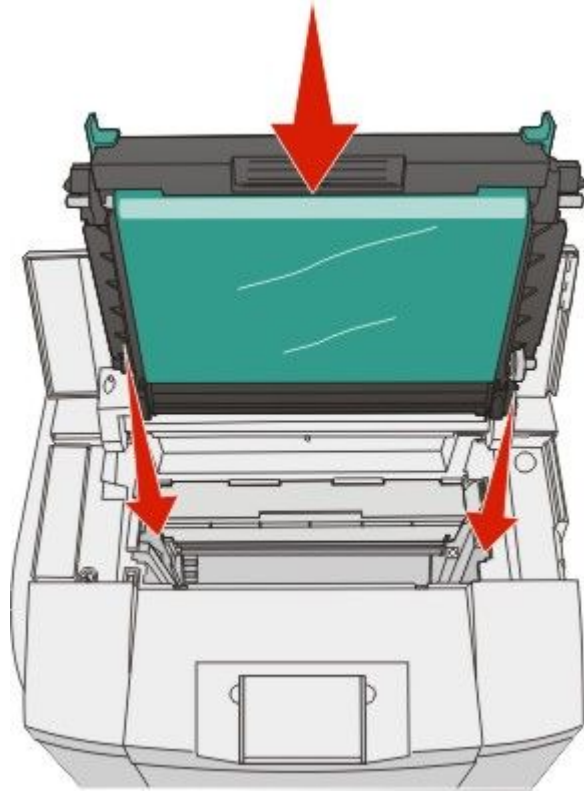

11 Push the latches away from each other to lock the photodeveloper cartridge into place.

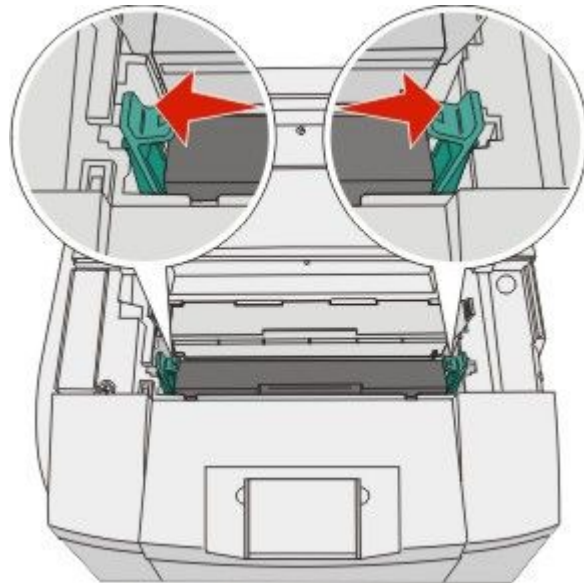

12 Close the top door.

13 Install the toner cartridges one at a time.

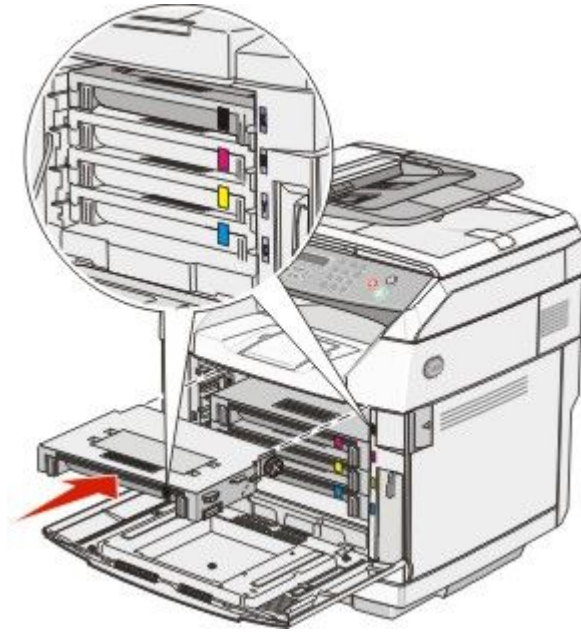

14 Close the front door.

15 Turn the printer on.

Ordering supplies

To order supplies in the U.S., contact Lexmark at 1-800-539-6275 for information about Lexmark authorized supplies dealers in your area. In other countries or regions, visit the Lexmark Web Site at www.lexmark.com or contact the place where you purchased the printer.

Note: All life estimates for printer supplies assume printing on letter- or A4-size plain paper.

Ordering toner cartridges

When **Toner Low <xxxx>** appears, order the specified new toner cartridge(s). The toner cartridge(s) of color “x” — K(black), Y(yellow), M(magenta), or C(cyan)—will soon be exhausted. The specified toner cartridge can print approximately 100–125 pages, depending on the coverage of the toner color, after the message first appears.

When **Toner Low <xxxx>** appears or when the print becomes faded, you may be able to extend the life of the toner cartridge(s):

- 1** Remove the toner cartridge(s).
- 2** Firmly shake the cartridge(s) side-to-side and front-to-back several times to redistribute toner.
- 3** Reinsert the toner cartridge(s) and continue printing.

Note: Repeat this procedure multiple times until the print remains faded, and then replace the cartridge(s).

The recommended toner cartridges specifically designed for your printer are:

Part name	Part number	For printer(s)
Cyan High Yield Toner Cartridge	C500H2CG	C500/X500/X502
Magenta High Yield Toner Cartridge	C500S2MG	C500/X500/X502
Yellow High Yield Toner Cartridge	C500H2YG	C500/X500/X502
Black High Yield Toner Cartridge	C500H2KG	C500/X500/X502
Cyan Toner Cartridge	C500S2CG	C500/X500/X502
Magenta Toner Cartridge	C500S2MG	C500/X500/X502
Yellow Toner Cartridge	C500S2YG	C500/X500/X502
Black Toner Cartridge	C500S2KG	C500/X500/X502

Ordering a fuser

When **Fuser Life: Replace Fuser** appears, replace the fuser immediately. For installation information, see the documentation that came with the fuser.

Part name	Part number
Fuser	C500X28G (120 V/50–60 Hz) C500X29G (220–240 V/50–60 Hz)

Ordering a photodeveloper cartridge

When **OPC Belt Life: Replace OPC** appears, replace the photodeveloper cartridge (OPC belt) immediately. For installation information, see the documentation that came with the photodeveloper cartridge.

Part name	Part number
Photodeveloper cartridge	C500X26G

Ordering a waste toner bottle

When **Waste Pack Full: Replace Waste Toner Pack** appears, order a replacement waste toner bottle.

Part name	Part number
Waste toner bottle	C500X27G

Moving the printer

Before moving the printer

⚠ CAUTION—POTENTIAL INJURY: The printer weighs 35 kg (77 lb); therefore, it requires at least three people to lift it safely. Use the handholds on the sides of the printer to lift it, and make sure your fingers are not under the printer when you set it down.



Follow these guidelines to avoid personal injury or printer damage:

- Use at least two people to lift the printer.
- Before moving the printer:
 - Turn it off using the power switch.
 - Unplug the power cord from the wall outlet.
 - Disconnect all cords and cables from the printer.
 - Remove all printer options.

Warning—Potential Damage: Damage to the printer caused by improper moving is not covered by the printer warranty.

Locking the scanner

- 1 From the control panel, press ▲.
- 2 Press ▲ or ▼ repeatedly until **Machine Settings** appears, and then press ✓.
- 3 Press ▲ or ▼ repeatedly until **Scanner Carriage** appears, and then press ✓.
- 4 Press ▲ or ▼ repeatedly until **Move to Lock** appears, and then press ✓.
- 5 Press ▲ or ▼ repeatedly until **Execute** appears, and then press ✓.
The scanner moves to the home position.
- 6 Press ✖ to return to the **Ready** state.

7 Open the scanner cover.



8 Move the Scanner lock switch to the locked position.



- 9 Close the scanner cover.



Removing the printer from the 530-sheet drawer

- 1 Turn the printer off, and then unplug the power cord from the wall outlet.
- 2 Disconnect all cables from the back of the printer.
- 3 Remove the right side cover by starting at the back of the printer and gently pulling each of the four slots off of its matching tab as you work your way to the front of the printer.

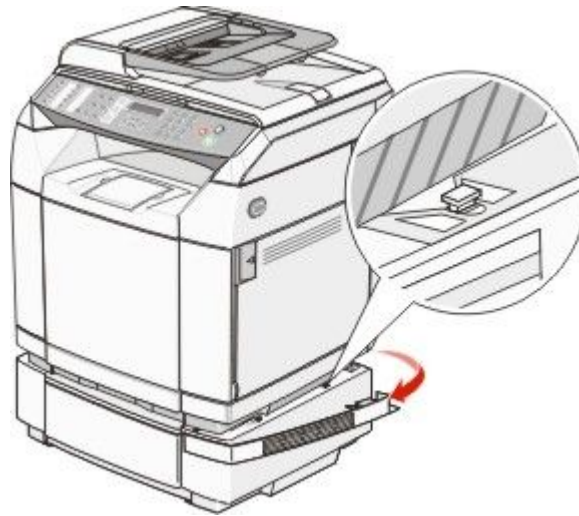

- 4 Remove the left side cover by starting at the back of the printer and gently pulling each of the four slots off of its matching tab as you work your way to the front of the printer.



- 5 Loosen the right thumbscrew, and remove the right bracket.



6 Loosen the left thumbscrew, and remove the left bracket.



7 Lift the printer off the drawer, and set the printer aside.

⚠ CAUTION—POTENTIAL INJURY: The printer weighs 35 kg (77 lb), and requires at least three people to lift it safely. Use the handholds on the sides of the printer to lift it, and make sure your fingers are not under the printer when you set it down.

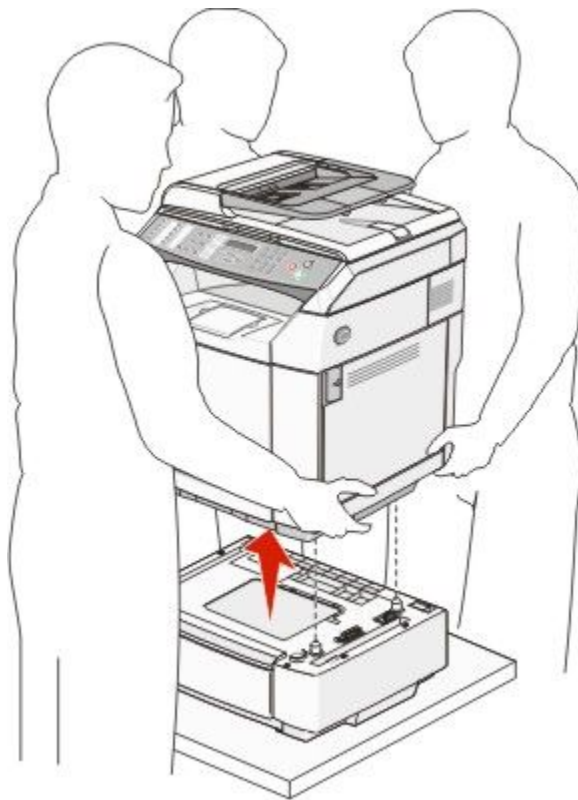

Moving the printer to another location

The printer and options can be safely moved to another location by following these precautions:

- Any cart used to move the printer must have a surface able to support the full footprint of the printer. Any cart used to move the options must have a surface able to support the dimensions of the options.
- Keep the printer in an upright position.
- Avoid severe jarring movements.

Setting the printer up in a new location

When the printer is set up, allow clearance around it as shown.

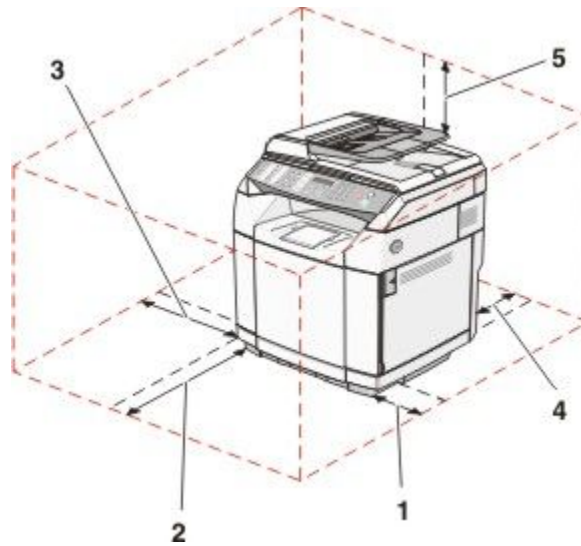

1	50 cm (8.0 in.)
2	70 cm (28.0 in.)
3	20 cm (8.0 in.)
4	25 cm (10.0 in.)
5	304.8 mm (12.0 in.)